

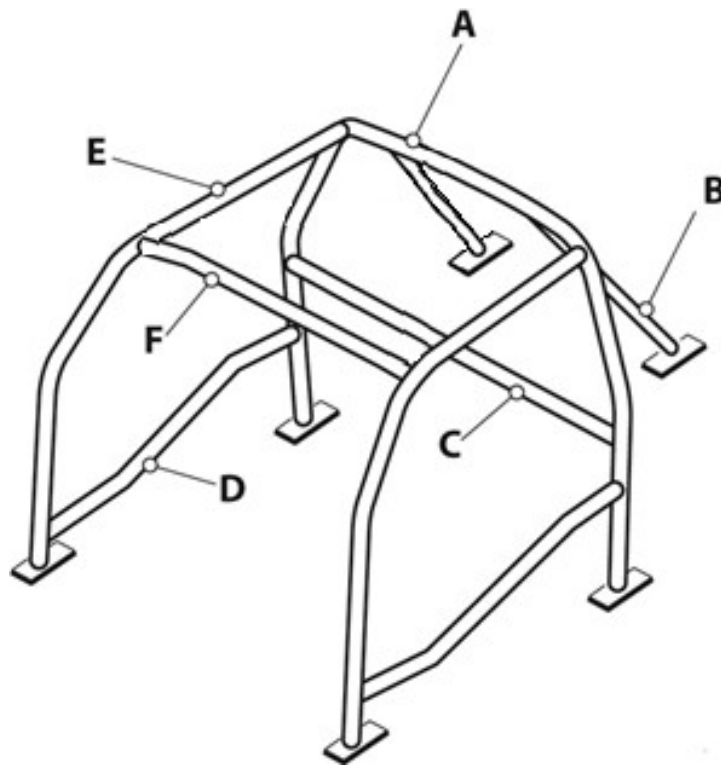

ANDRA Technical Bulletin – Rollcages for vehicles 6.499 seconds (1/4 mile) or quicker.

ANDRA Technical would like to remind drag racers who currently race under ANDRA or intend to race under ANDRA of the following rollcage requirements for sedan-based vehicles with a performance of 6.499 seconds (1/4 mile) / 4.139 seconds (1/8 mile), or quicker, that the rollcage must meet Top Doorslammer regulations or SFI 25.1D as a minimum, examples of which are shown on page two of this bulletin. This requirement which may have previously been missed by non-regular ANDRA Championship racers was within the Top Sportsman class regulations and has been in effect since the 1st of January 2015. The current ANDRA rulebook re-clarifies this requirement which is now within the rollcage section.

Below is an example of a fully welded Six Point Rollcage which meets the minimum design requirements of the current ANDRA Rollcage Specifications and is compliant for sedan-based vehicles with a performance of 9.999 to 6.500 seconds (1/4 mile) / 6.368 to 4.139 seconds (1/8 mile).



A Six Point Rollcage must have the following components as a minimum and in the positions illustrated in the image above.

- A. One Main Hoop
- B. Two Rear Stays
- C. One Taxi Bar (can be one-piece, two-piece or more where Diagonal Support/s are used)
- D. Two Side Intrusion Bars
- E. Two Forward Supports
- F. One Front Roof Support
- G. A one-piece Diagonal Support within the Main Hoop is also highly recommended.

If you want more information on the ANDRA Rollcage Specifications please contact technical@andra.com.au





Below are some examples of a SFI 25.1D rollcage which is compliant for sedan-based vehicles with a performance of 6.499 seconds (1/4 mile) / 4.139 seconds (1/8 mile), or quicker.

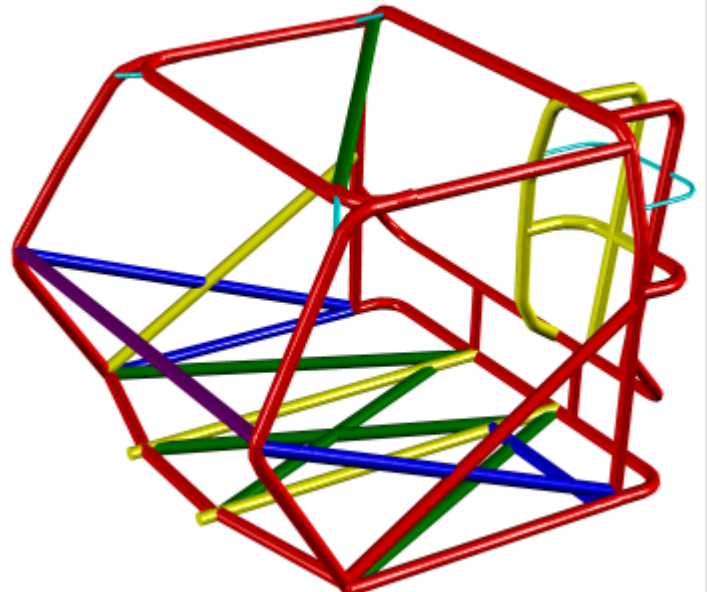
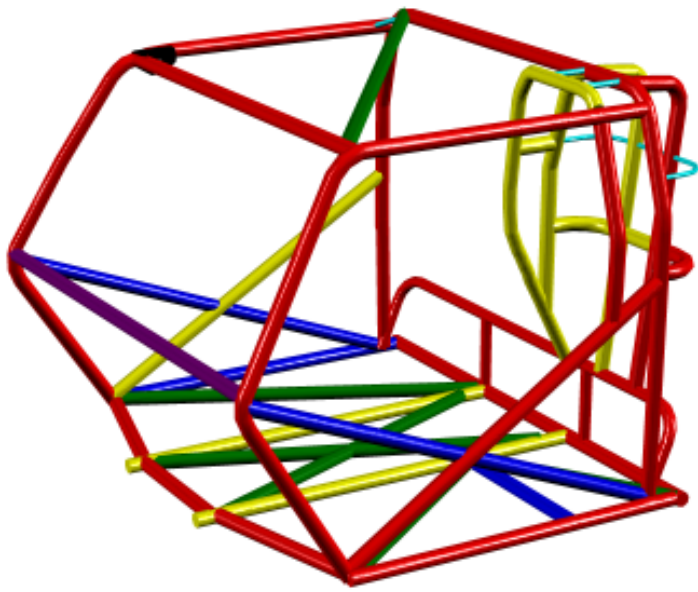
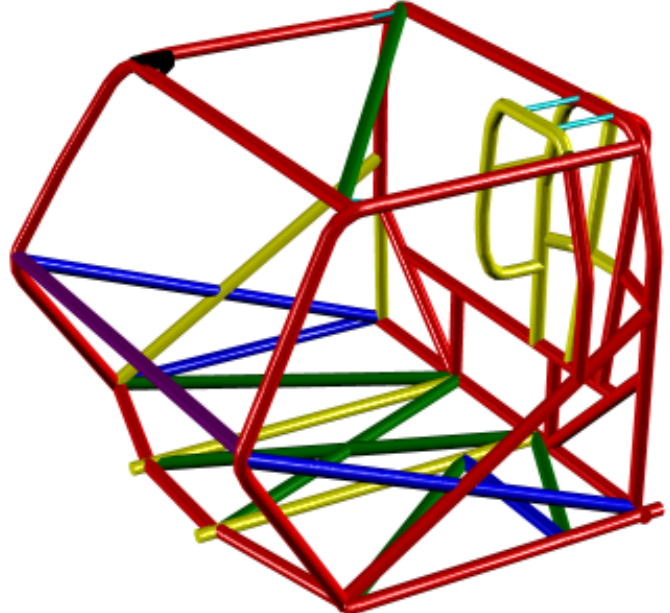
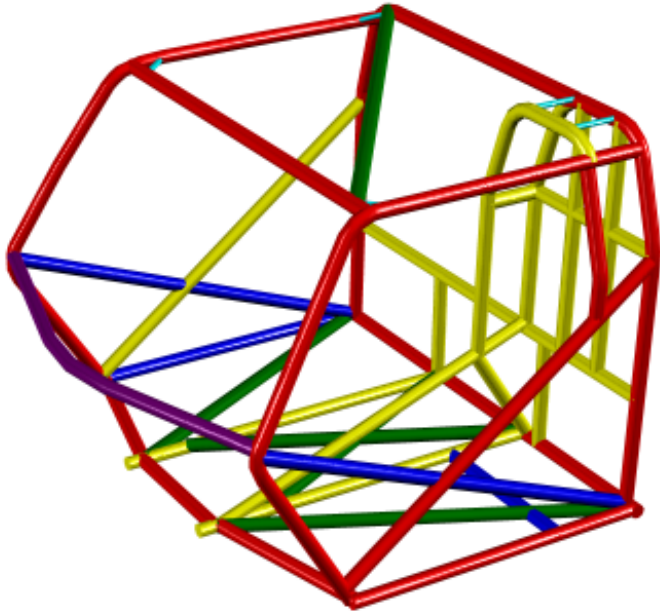

As can be seen from the images above, the complexity and structural integrity of the SFI designs are far superior to the minimum requirements of the ANDRA Six Point Rollcage.

If you want more information on the SFI specifications, which can be purchased from ANDRA (under licence from SFI), please contact technical@andra.com.au

Thanks, ANDRA Technical Officer.

